

Technical Specifications

EVERTUFF™ EXTRUDED CONCAVE BOLLARD

Primary Application

Stylish, solid and innovative the **Evertuff™ Concave Bollard** from Cosset helps you cost effectively add style and a distinctive look to your project. Either as a stand alone bollard, part of a post and rail or post and rope system, the concave bollard fits the bill. **Evertuff™ Concave Bollards** are easy to install and available in a range of options to suit any project. Rot free, rust free and vermin proof, they are a long term investment particularly in harsh conditions. Suitable for deterring vehicle access, the extruded concave bollard is extremely robust but, most importantly, unlike metal or wood alternatives will remain robust for the life of the product. Extruded **Concave Bollards** will also retain their highly aesthetic appearance for their lifetime.

Features

- Recycled co-mingled material means timber-like strength with no warping.
- Order pre-cut to length and therefore no wastage.
- Drilled, planed and cut with the same tools as timber.
- Won't crack like concrete, rot like timber or rust like steel.
- Termite and white ant resistant to ensure longevity for your project.
- Superior life span with the advantage of retaining physical properties throughout entire product life.
- Non toxic – no chemicals like CCA treated timber.
- UV stabilised material guarantees longevity of product.
- Curved edges and protrusion free giving a safety first design.
- 98% recycled plastic and timber material means each metre of Evertuff™ prevents kilograms of rubbish entering landfill, thus organisations can reduce their environmental footprints.
- Non permeable – can be fully submerged in water.
- Will not harbour vermin.
- Smooth finish and consistent colouring – unlike moulded methods, extrusion allows for a smooth wood-like finish and is far more colour consistent.
- 8 x stronger than pure plastic recycled products.
- Has a thermal buffer and hence will not freeze over or get too hot to touch.

Options

- Available with 65mm hole to suit 50mm (ID) for Blue Galv. Pipe Post and Rail system.
- Available in standard charcoal only.



© Cosset Industries Australia Pty Ltd

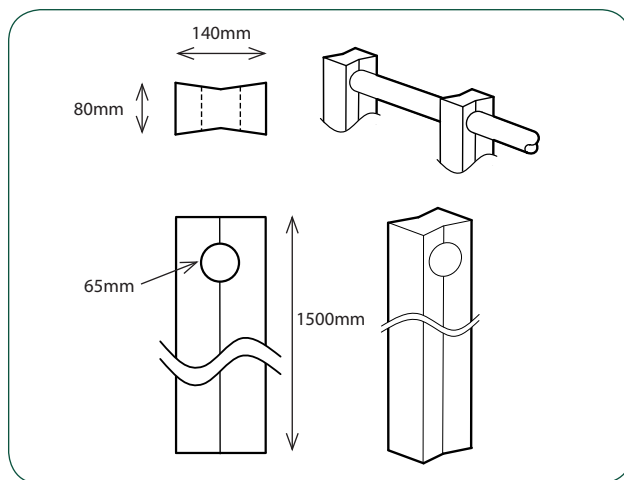

Models

- Model Code (ES-CB) – No Hole**
- Model Code (ES-CBH) – 65mm Hole**

Bollard Length (BL)
Standard Length 1500mm
Hole
Maximum rail O.D. 64mm

Example :
Cosset-ES-**CB**-1500
Cosset concave bollard 1500mm

D Chart

| Model Code | Height (mm) | Width (mm) | Max Section Length (mm) | Weight (kg/m) |
|------------|-------------|------------|-------------------------|---------------|
| ES-CB | 80 | 140 | 1500 | 10.2 |

For a custom **Bollard** made specifically for your organisation please contact Cosset on 1800 COSSET

How To Specify :

COSSET - **ES** - **CB** - **BL**
 | | |
 Manufacturer Model Code Section Length