

Technical Specifications

SWINGBIN

Primary Application

Cosset's **SwingBin** is acknowledged as the most innovative bin retaining system available with unique access for those with a wheelchair, walking frame, or electric scooter.

The **SwingBin** was developed in conjunction with both disability rehabilitation groups and Local Government and is arguably the most hygienic street litter bin retaining system available. Sealed when not in use, the user need only to push the base of the bin by foot, wheelchair, walking frame or motorized scooter to open and dispose of litter without having to touch the lid.

SwingBin takes the standard 120L MGB and suspends it from a compact and robust frame which is fixed to any surface via its own base plate.

The bin can also be opened by hand to a predetermined width and a key lock makes litter removal quick and simple. All of the benefits of the standard MGB are retained, including compatibility with existing litter removal systems.

SwingBin offers customers new and genuine advantages over existing designs while fitting easily into public open spaces. It creates a new standard in the disposal of public litter for both the able-bodied and those with limited mobility.

Features

- Offers hygienic, hands free operation.
- Lid remains closed unless in use.
- Simplicity, with the opening mechanism using only one moving part.
- Available in any colour.
- Limited mobility access.
- Using MGB's enables the bin to be emptied without manual lifting.
- Robust construction, 3mm mild steel, undercoated, powder coated and clear coated ensures long life and reliable operation.
- Small footprint means it can be easily retrofitted to existing bin site.

Accessories

For a Padlock to suit SwingBin Specify Code: **Cosset-SB-PL**

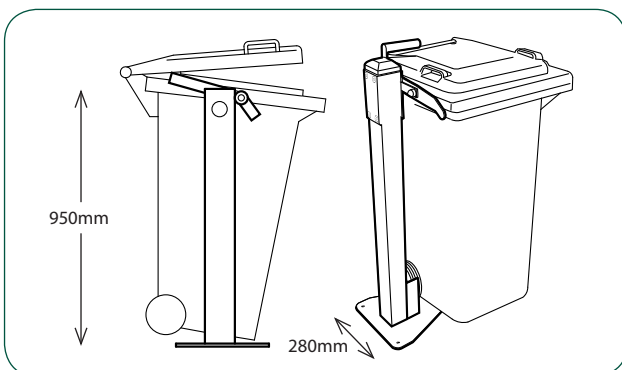

© Cosset Industries Australia Pty Ltd

MGB not included

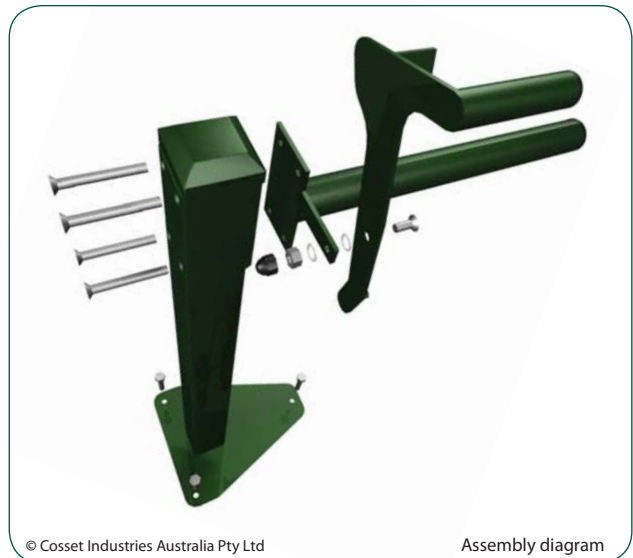

© Cosset Industries Australia Pty Ltd

Assembly diagram

SWINGBIN

Models

Model Code (SB)

Dimensions

Height 950mm, Width 280mm

Colours (CC)

Specify colour by word or

Specify colour by Pantone Colour Matching System.

Weight

16.5kg

Example :

Cosset-SB-**GREEN**
SwingBin in Green

Example :

Cosset-SB-**243**
SwingBin in colour Pantone 243

How To Specify :

